



GLADDING, McBEAN

# VITRIFIED CLAY PIPE



[www.gladdingmcbean.com](http://www.gladdingmcbean.com)

THE SUSTAINABLE CHOICE FOR SEWER INFRASTRUCTURE



**GLADDING, McBEAN**  
**VITRIFIED CLAY PIPE (VCP)**  
150 Years of Strength & Sustainability

For more than 150 years, Gladding, McBean has produced high-performance vitrified clay pipe (VCP) for gravity sanitary sewer systems serving municipalities, engineers, and contractors. Since 1875, our pipe has delivered exceptional structural strength, hydraulic performance, and long-term durability in demanding underground environments. Built to industry standards and proven in the field, it provides reliable infrastructure designed to last for generations.

### Performance Advantages

- ✓ Manufactured to ASTM standards and regional specifications, including Greenbook
- ✓ High-compressive strength with dense vitrified ceramic structure.
- ✓ Low water absorption and excellent dimensional stability
- ✓ Superior resistance to abrasion, loading, and groundwater infiltration
- ✓ Resistant to chemical attack from wastewater and aggressive soils
- ✓ Proven service life exceeding 100 years

### Sustainable Infrastructure

- ✓ Manufactured from natural clay materials
- ✓ Minimal maintenance required
- ✓ Reduced life cycle environmental impact
- ✓ Supports resilient municipal sewer systems

Engineered for **Durability**. Built for **Generations**.

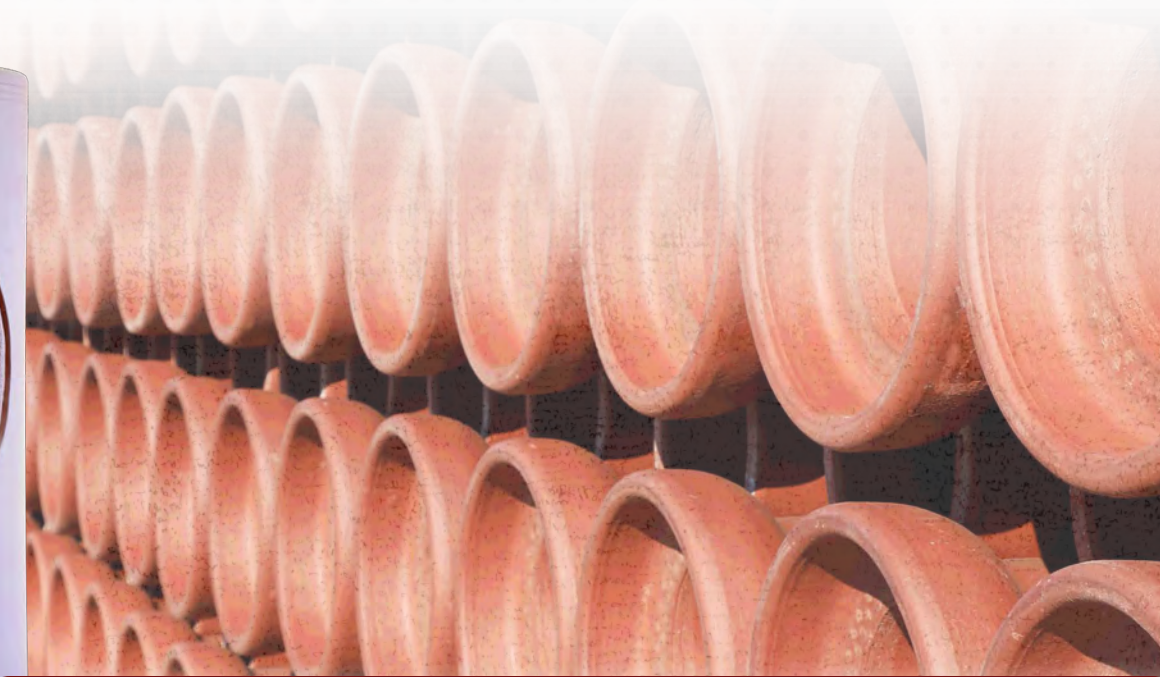

✓ **PROVEN PERFORMANCE**

✓ **MINIMAL MAINTENANCE**

✓ **LOW LIFE CYCLE COSTS**

✓ **BUILT FOR GENERATIONS**

### Product Availability & Support

- ✓ Standard stock range available
- ✓ Custom lengths, joints, coatings, and specialty products available by special order
- ✓ Engineering and technical support for pipe selection, design, installation, and regulatory compliance.



**Request a Visit.** To contact our Engineering Services Department and arrange a visit to our manufacturing plant located in Lincoln, California, please **SCAN THE QR CODE**.



## Environmental Product Declaration

Gladding, McBean Vitrified Clay Pipe (VCP) is supported by an independently verified Type III EPD from the National Clay Pipe Institute (NCPI) following ISO 14025 and Life Cycle Assessment standards (ISO 14040/ISO 14044). The EPD provides transparent environmental performance data representing North American vitrified clay pipe production.

## SUSTAINABLE VITRIFIED CLAY PIPE PRODUCTION



### 1 NATURAL CLAY

Locally sourced clay is extracted and mixed with water. 100% natural materials



### 2 PREPARATION

Clay is blended, extruded, formed into pipe, and air-dried prior to firing.



### 3 FIRING

Pipes are kiln-fired at over 2000°F to form dense vitrified ceramic.



### 4 APPLICATION OF *SPEED SEAL*<sup>®</sup>

Precision coating applied to protect all edges, joints are configured for consistent quality.

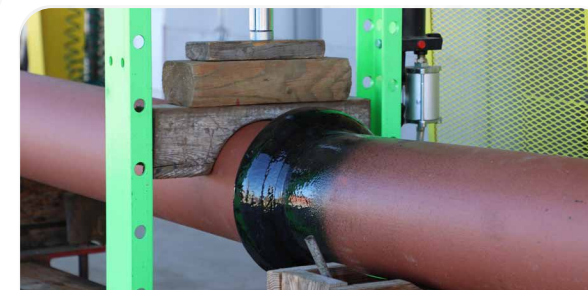

### 5 QUALITY CONTROL

Each pipe is carefully inspected to ensure consistent high quality production.



### 6 END USE & DELIVERY

Pipes are delivered to sites for sewer systems.

### Sustainability Highlights

### Supporting Sustainable Infrastructures

- ✓ Cradle-to-grave life cycle assessment covering raw materials through end of life
- ✓ 150-year reference service life, reflecting long-term Infrastructure performance
- ✓ No operational energy of water demand during service life
- ✓ No Scheduled structural replacement required
- ✓ At end of life, pipes are typically abandoned in place, avoiding demolition and landfill impacts.

- ✓ Embodied carbon reporting and EC3 tool compatibility
- ✓ Municipal sustainability and ESG programs
- ✓ Infrastructure life-cycle assessment and carbon modeling
- ✓ Green procurement and environmental disclosure requirements
- ✓ A long service life helps reduce overall lifecycle costs

## QC Lab

Gladding, McBean maintains a comprehensive Quality Assurance program in accordance with ASTM C700, C425, C828, C896, C109, and C301, as well as the requirements of the Standard Specifications for Public Works Construction (Green Book). Vitrified clay pipe undergoes systematic testing and inspection to ensure compliance with applicable standards and project specifications. Products are independently listed and certified by IAPMO Research and Testing, Inc., including ongoing inspection and surveillance to verify continued compliance and quality.



Three-edge bearing testing for inherent structural strength

## Routine Laboratory Testing

From raw material evaluation through forming, firing, joint assembly, and final inspection, every product is verified to deliver consistent performance in demanding sewer infrastructure applications. Our routine laboratory testing includes:

- **Structural strength** verification
- **Joint performance** evaluation
- **Water absorption** testing
- **Dimensional tolerance** verification
- **Visual inspection** for workmanship

Independent third-party laboratories and consulting engineers also perform verification testing to ensure regulatory compliance.



Compression joint test simulates joint performance under condition of shear and angular deflection



Hydrostatic Test Setup



Joint performance and pressure testing

Gladding, McBean vitrified clay sewer pipe and fittings are IAPMO R&T listed to ASTM C700 and compliant with UPC® and IPC® codes, ensuring proven performance and reliability.

Scan the QR code for certification details.





**Guard Technology—Engineered Protection from Plant to Placement**

Automated robotic coating application ensures consistent protection.



## **PRECISION. CONSISTENCY. CONTROL.**

Developed by Gladding, McBean, **G-MAX™ Guard Technology** is a high-performance protective coating applied to vitrified clay pipe bells to reduce impact damage during handling, transportation, and installation.

The coating is engineered for high abrasion resistance, impact resistance, and long-term flexibility. It forms a seamless, fast-curing protective layer that provides a resilient, compressive cushion around the bell area, helping protect against edge chipping, and damage caused by loading, unloading, stacking, and field handling.

Application is performed using an automated robotic spray equipment, ensuring controlled material ratios, uniform thickness, and consistent coverage at the joint interface.

The coating is non-bonded to the vitrified clay surface and does not adhere to the clay body. It can be cleanly cut and removed at any time to allow direct inspection of the underlying pipe surface and joint geometry.

**G-MAX™ Guard Technology** does not alter the structural or hydraulic performance of the pipe. It functions solely as a protective system designed to reduce handling-related damage prior to and during installation.

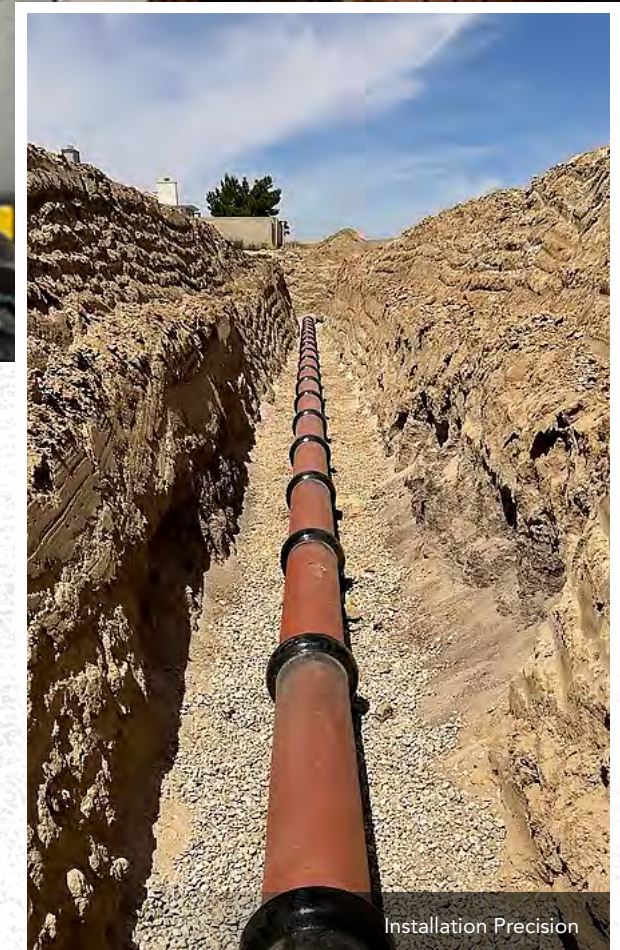

Installation Precision

# STANDARD BELL & SPIGOT

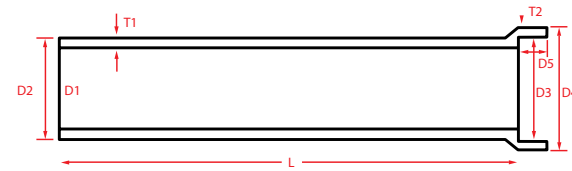

D1	L	WEIGHT PLF	D2 BARREL OD	D3 BELL ID	D4 BELL OD	D5 BELL DEPTH	T1 BARREL THICK	T2 BELL THICK
4"	1', 2', 4'	11 lb	5.33	6.47	7.58	1.91	0.72	0.70
6"	1', 2', 5'	21 lb	7.89	8.95	10.68	2.21	0.82	0.81
8"	1', 2', 6'	30 lb	10.00	11.46	13.26	2.28	0.87	0.90
10"	1', 2', 6'	44 lb	12.67	13.80	16.31	2.63	1.19	1.12
12"	1', 2', 6'	54 lb	14.65	15.40	18.68	2.82	1.38	1.22
15"	1', 2', 6'	90 lb	18.32	19.29	23.23	2.80	1.68	1.48
18"	1', 2', 6'	141 lb	21.69	22.95	26.90	3.25	2.02	1.51
21"	1', 2', 6'	168 lb	25.60	26.99	30.91	3.59	2.20	1.60
24"	1', 2', 6'	230 lb	28.85	30.83	34.61	3.71	2.61	1.69
27"	1', 2', 6'	290 lb	32.75	35.09	38.46	4.00	3.00	1.75
30"	1', 2', 6'	333 lb	35.77	38.05	42.03	3.96	3.09	1.96
33"	1', 2', 6'	415 lb	39.28	41.40	45.92	4.00	3.16	2.25
36"	1', 2', 5.5'	445 lb	42.71	45.39	49.21	4.03	3.60	2.18
39"	1', 2', 5.5'	540 lb	46.35	49.28	54.51	4.18	3.60	2.55
42"	1', 2', 5.5'	603 lb	49.59	52.72	58.14	4.46	3.96	2.63

NOMINAL PIPE SIZE	STANDARD LENGTHS	ASTM C-700 EXTRA STRENGTH		SSPWC "GREEN BOOK" EXTRA STRENGTH		SSPWC "GREEN BOOK" EXTRA STRENGTH	
		LB.F/ LINEAR FT	(KN/ LINEAR M)	LB.F/ LINEAR FT	(KN/ LINEAR M)	LB.F/ LINEAR FT	(KN/ LINEAR M)
4"	1', 2', 4'	2000	(29.2)	2000	(29.2)	2600	(37.9)
6"	1', 2', 5'	2000	(29.2)	2000	(29.2)	2800	(40.8)
8"	1', 2', 6'	2200	(32.1)	2200	(32.1)	3100	(45.2)
10"	1', 2', 6'	2400	(35.0)	2400	(35.0)	3600	(52.5)
12"	1', 2', 6'	2600	(37.9)	2600	(37.9)	3900	(56.9)
15"	1', 2', 6'	2900	(42.3)	3100	(45.2)	3700	(53.9)
18"	1', 2', 6'	3300	(48.2)	3600	(52.5)	4400	(64.2)
21"	1', 2', 6'	3850	(56.2)	4200	(61.3)	5000	(72.9)
24"	1', 2', 6'	4400	(64.2)	4800	(70.2)	5800	(84.6)
27"	1', 2', 6'	4700	(68.6)	5200	(75.9)	6200	(90.4)
30"	1', 2', 6'	5000	(73.0)	5500	(80.3)	6700	(97.7)
33"	1', 2', 6'	5500	(80.3)	5800	(84.6)	7000	(102.1)
36"	1', 2', 6'	6000	(87.6)	6300	(91.9)	7500	(109.4)
39"	1', 2', 5.5'	6600	(96.3)	6600	(96.3)	8000	(116.7)
42"	1', 2', 5.5'	7000	(102.2)	7000	(102.2)	8400	(122.5)

MINIMUM 3-EDGE BEARING STRENGTH

NOTE: 1. The above dimensions are average measurements and do not reflect the actual tolerances. 2. The above weights are average weights and do not reflect the actual tolerances. 3. The above pipe lengths are standard stock lay lengths. We also regularly manufacture custom lengths.

# BENDS

Mitered bends 1/4 (90deg) and 1/8 (45deg) available in 4" - 42", 1/16 (22-1/2deg) available in 6" - 42".

## MITERED 1/4 OR 90° BEND

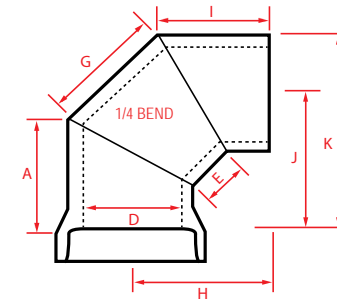

## MITERED 1/8 OR 45° BEND

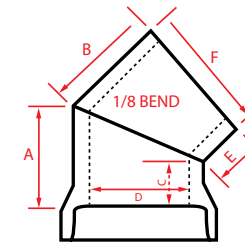

## MITERED 1/16 OR 22.5° BEND

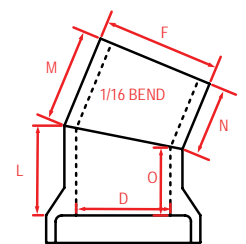

D	A	B	C	E	F	G	H	I	J	K	L	M	N	O
6"	6.25"	8.50"	3.25"	4.0"	7.88"	7.50"	9.25"	8.00"	8.00"	12.00"	5.00	7.00	5.75	3.25
8"	7.63"	8.00"	3.63"	4.0"	10.00"	8.00"	9.25"	8.00"	9.25"	14.25"	5.50	7.00	5.75	3.75
10"	8.63"	9.00"	3.63"	4.0"	12.50"	11.50"	10.25"	8.63"	10.25"	16.25"	6.75	8.00	6.00	4.00
12"	9.75"	9.75"	3.88"	4.0"	14.50"	12.63"	11.75"	9.75"	11.75"	19.25"	*	*	*	*
15"	12.75"	11.63"	5.00"	4.0"	18.25"	19.13"	17.13"	12.75"	17.00"	26.13"	*	*	*	*
18"	14.00"	14.00"	5.00"	5.0"	21.88"	23.00"	19.50"	14.00"	19.50"	30.50"	*	*	*	*
21"	16.00"	16.00"	5.50"	5.5"	25.50"	26.63"	22.13"	16.00"	22.13"	34.88"	*	*	*	*
24"	18.00"	18.00"	6.00"	6.0"	29.00"	30.00"	24.50"	18.00"	24.75"	39.25"	*	*	*	*
37"	20.50"	20.50"	6.50"	6.5"	33.75"	34.50"	28.00"	20.50"	28.00"	44.88"	*	*	*	*
30"	22.00"	22.00"	7.00"	7.0"	36.00"	36.75"	30.25"	22.00"	30.25"	48.25"	*	*	*	*
33"	23.88"	23.88"	7.50"	7.50"	39.50"	40.25"	32.63"	23.88"	32.36"	52.38"	*	*	*	*
36"	25.63"	25.63"	8.00"	8.00"	42.63"	43.25"	35.00"	25.63"	35.00"	56.38"	*	*	*	*
39"	28.00"	28.00"	8.50"	8.50"	47.00"	47.50"	37.50"	28.00"	37.50"	61.00"	*	*	*	*
42"	29.75"	29.75"	9.00"	9.00"	50.25"	50.50"	40.5"	29.75"	40.50"	63.25"	*	*	*	*

\* Contact sales team for dimensions and details.

## WYES

Branches are made approximately 45 degrees to the barrel.

Standard Wye available from 4" through 21". Specialty wyes available from 24" through 33".

WYE



REVERSE WYE

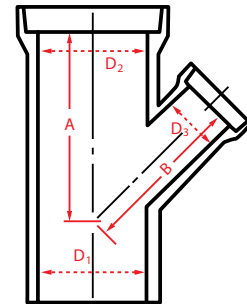

D1 & D2	D3	A	B	BARREL DIAMETER	SPUR DIAMETER	A	B
4"	4"	11"	9-11/16"	24"	6"	25-5/8"	27-5/8"
6"	4"	12-5/16"	11-1/2"	24"	8"	27-5/8"	28-3/4"
6"	6"	14-5/16"	12-9/16"	24"	10"	29-1/8"	30-3/8"
8"	4"	13-3/8"	13"	24"	12"	31-1/8"	31-3/4"
8"	6"	15-3/8"	14"	24"	15"	32-1/8"	33-5/8"
8"	8"	16-7/8"	15-1/8"	27"	6"	28-1/8"	30-1/8"
10"	4"	14-3/8"	14-9/16"	27"	8"	30-1/8"	31-1/4"
10"	6"	16-3/8"	15-5/8"	27"	10"	31-5/8"	32-7/8"
10"	8"	18-3/8"	16-3/4"	27"	12"	33-5/8"	34-1/4"
10"	10"	20-3/8"	18-3/8"	27"	15"	34-5/8"	36-1/8"
12"	4"	15-3/4"	16-1/4"	30"	6"	30-1/8"	32-7/16"
12"	6"	17-5/8"	17-1/4"	30"	8"	32-1/8"	33-1/2"
12"	8"	19-5/8"	19"	30"	10"	34-1/8"	35-1/4"
12"	10"	21-5/8"	20"	30"	12"	35-5/8"	36-1/2"
12"	12"	23-1/8"	21-3/8"	30"	15"	36-1/8"	38-7/16"
15"	6"	19-5/8"	19-7/8"	33"	6"	32-1/2"	34-7/8"
15"	8"	21-5/8"	21"	33"	8"	34"	36"
15"	10"	22-1/8"	22-5/8"	33"	10"	36"	37-5/8"
15"	12"	25-1/8"	24"	33"	12"	37-1/2"	39"
15"	15"	26-5/8"	25-7/8"	33"	15"	37-1/2"	40-7/8"
18"	6"	21-7/8"	22-11/16"	36"	6"	34-1/2"	37-3/16"
18"	8"	23-7/8"	23-13/16"	36"	8"	36-1/2"	38-5/16"
18"	10"	25-7/8"	25-7/16"	36"	10"	38-1/2"	39-15/16"
18"	12"	26-7/8"	26-13/16"	36"	12"	39"	41-5/16"
18"	15"	29-7/8"	28-11/16"	36"	15"	39"	43-3/8"
21"	6"	23-7/8"	25-1/16"	39"	6"	36-3/8"	40"
21"	8"	25-7/8"	26-3/16"	39"	8"	38-3/8"	41-1/8"
21"	10"	27-7/8"	27-13/16"	39"	10"	40-3/8"	42-3/4"
21"	12"	29-7/8"	29-3/16"	39"	12"	41-3/8"	44-1/8"
21"	15"	30-7/8"	31-1/16"	39"	15"	41-3/8"	46"

## TEES

Branches are made approximately 90 degrees to the barrel.

Standard Tee available from 4" through 21". Specialty tees available from 24" through 42".

TEE



DOUBLE TEE

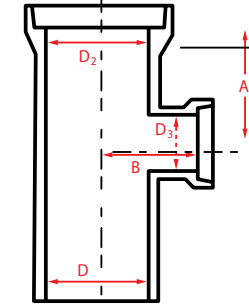

D1 & D2	D3	A	B	D1 & D2	D3	A	B
4"	4"	6"	6-1/16"	24"	6"	25-5/8"	27-5/8"
6"	4"	6-1/16"	7-5/16"	24"	8"	27-5/8"	28-3/4"
6"	6"	7-1/16"	7-1/8"	24"	10"	29-1/8"	30-3/8"
8"	4"	6-3/8"	8-3/8"	24"	12"	31-1/8"	31-3/4"
8"	6"	7-3/8"	8-3/16"	24"	15"	32-1/8"	33-5/8"
8"	8"	8-3/8"	8-1/4"	27"	6"	28-1/8"	30-1/8"
10"	4"	6-3/8"	9-1/2"	27"	8"	30-1/8"	31-1/4"
10"	6"	7-7/8"	9-5/16"	27"	10"	31-5/8"	32-7/8"
10"	8"	8-7/8"	9-3/8"	27"	12"	33-5/8"	34-1/4"
10"	10"	9-7/8"	9-7/8"	27"	15"	34-5/8"	36-1/8"
12"	4"	6-5/8"	10-5/8"	30"	6"	30-1/8"	32-7/16"
12"	6"	8-1/8"	10-7/16"	30"	8"	32-1/8"	33-1/2"
12"	8"	9-1/8"	10-1/2"	30"	10"	34-1/8"	35-1/4"
12"	10"	10-1/8"	11"	30"	12"	35-5/8"	36-1/2"
12"	12"	11-1/8"	11-1/4"	30"	15"	36-1/8"	38-7/16"
15"	6"	8-1/8"	12-5/16"	33"	6"	32-1/2"	34-7/8"
15"	8"	9-1/8"	12-3/8"	33"	8"	34"	36"
15"	10"	10-1/8"	12-7/8"	33"	10"	36"	37-5/8"
15"	12"	11-5/8"	13-1/8"	33"	12"	37-1/2"	39"
15"	15"	13-1/8"	13-1/8"	33"	15"	37-1/2"	40-7/8"
18"	6"	8-3/8"	14-5/16"	36"	6"	34-1/2"	37-3/16"
18"	8"	9-3/8"	14-3/8"	36"	8"	36-1/2"	38-5/16"
18"	10"	10-3/8"	14-7/8"	36"	10"	38-1/2"	39-15/16"
18"	12"	11-7/8"	15-1/8"	36"	12"	39"	41-5/16"
18"	15"	12-7/8"	15-1/8"	36"	15"	39"	43-3/8"
21"	6"	8-3/8"	16"	39"	6"	36-3/8"	40"
21"	8"	9-3/8"	16-1/16"	39"	8"	38-3/8"	41-1/8"
21"	10"	10-7/8"	16-9/16"	39"	10"	40-3/8"	42-3/4"
21"	12"	11-7/8"	16-13/16"	39"	12"	41-3/8"	44-1/8"
21"	15"	13-3/8"	16-13/16"	39"	15"	41-3/8"	46"

## DOUBLE WYES

Branch connections are formed at an approximate 45-degree angle to the main barrel. Standard wye sizes are available from 4" through 21". Specialty wyes are available from 24" through 33".

### DOUBLE WYE

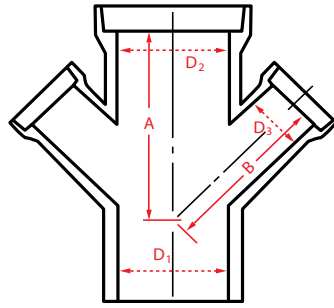

D1	D2	D3	A	B
4"	4"	4"	11"	9-11/16"
6"	6"	4"	12-5/16"	11-1/2"
6"	6"	6"	14-5/16"	12-1/2"
8"	8"	6"	15-3/8"	14"

Note: Dimensions A and B are approximate.

## SWEEPS

### SWEEP 1/16 OR 22°



Available in 4" - 8"

### SWEEP 1/8 OR 45° BEND



Available in 4" - 8"

### SWEEP 1/4 OR 90°



Available in 4" only

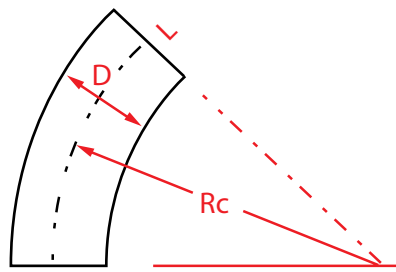

D	RC	L
4"	17"	10"

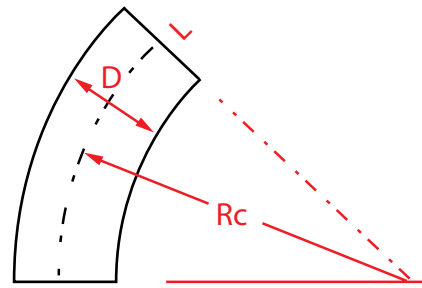

D	RC	L
4"	10-1/4"	13-1/2"

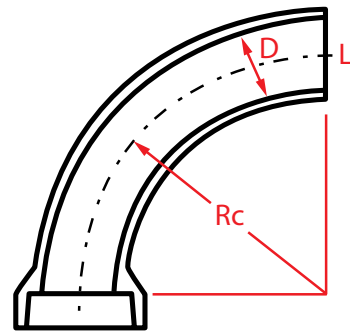

D	RC	L
4"	9-1/2"	26"

## REDUCERS

Available in 4" - 42". Dimensions for 4" - 8" shown below.

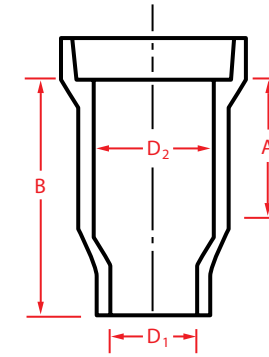

D1	D2	A	B
4"	6"	7"	12"
6"	8"	7"	15"
8"	10"	7"	18"

## INCREASERS

Available in 4" - 42". Dimensions for 4" - 8" shown below.

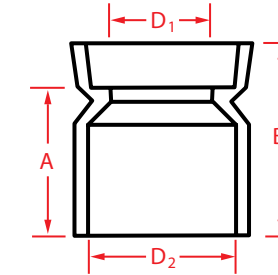

D1	D2	A	B
4"	6"	6-1/8"	8"
6"	8"	17-1/2"	19-3/4"
8"	10"	17-3/8"	20"

## TRANSITIONAL STUBS

Used to join plain-end rubber coupling pipe to the bell end of SPEED-SEAL™



## STOPPERS

Poly cap stoppers are not recommended in areas subject to ground water.

**CLAY STOPPER  
(8" THRU 24")**



**POLYCAP STOPPER  
(4" THRU 8")**



## SPECIALTY ITEMS

For dimensions and details please send inquiry

**ALTERNATE PIPE VCP CONNECTIONS**



**HANDHOLE TRAP**



**WYE-TEE COMBINATION**



**DROP MANHOLE TEE**



**DROP MANHOLE DOUBLE TEE**



**DROP MANHOLE 1/4 BEND**



## SADDLES

**PLAIN TEE SADDLE**



**COLLAR TEE SADDLE**



**PLAIN WYE SADDLE**



**COLLAR WYE SADDLE**

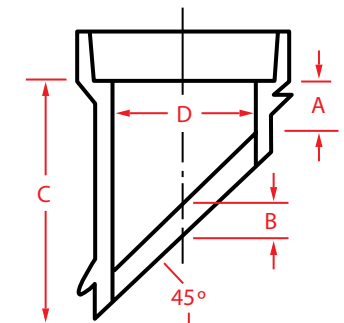
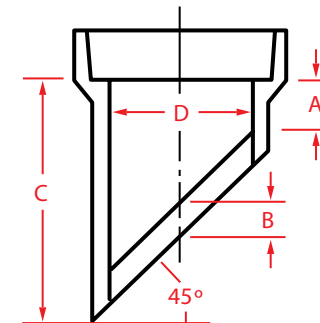

D	A	B	C
4"	1-1/2"	1-1/2"	6-1/2"
6"	2"	1-1/2"	9"
8"	2-1/2"	1-1/2"	12"

D	A	B	C
4"	1-1/2"	1-1/2"	6-1/2"
6"	3"	1-1/2"	9"
8"	3-1/2"	1-1/2"	12"

# BANDED RUBBER COUPLINGS AND TRANSITIONAL BUSHING FOR RUBBER COUPLINGS

Used for the joining of regular or field-cut plain-end vitrified clay pipe.

### RUBBER COUPLING

Available in sizes 4" - 12"



### SEWER REPAIR COUPLING

Available with outside stainless steel shear ring sizes 4" - 42"



### TAP-N-TEE SADDLE

Available in sizes 4" - 8"

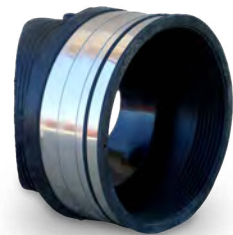

### TRANSITIONAL BUSH

For connecting other pipe materials to vitrified clay pipe (VCP) using rubber couplings. Provides a secure, watertight transition between pipe systems.



## SPECIFICATIONS

The Vitrified Clay Pipe products manufactured by Gladding, McBean are designed to exceed all applicable requirements of both the ASTM Standards and the "GREENBOOK" Standard Specifications for Public Works Construction.

Below is a table depicting a synopsis of specifications applicable to Vitrified Clay Pipe products. Please contact our staff to request additional information or to obtain a copy of any standard.

Item	SYNOPSIS OF SPECIFICATIONS APPLICABLE TO VITRIFIED CLAY PIPE PRODUCTS		
	"Green Book" SSPWCA	ASTM	AASHTO
1. Specification for strength.	Section 207-8	C700	M65
2. Specification for compression joints.	Section 208-2.3	C425	
3. Standard test methods.	Section 207-8.5	C301	
4. Standard installation practice		C12	

## CURVED SEWER INSTALLATIONS

The design and installation of curved sewer pipelines is common. Bends and curves to accommodate both grade and alignment changes are commonly accomplished by the deflection of straight pipe or by the use of mitered bends, beveling the joints or any combination thereof.

We manufacture mitered bends in sizes 4" to 42" to accommodate any change in angle designed by the engineer. The deflection of standard straight pipe generally provides the required change in grade or alignment. Utilizing shorter pipe lengths decreases the allowable radius. We are providing the following to assist you in such designs.

When it is necessary to use curvilinear alignment due to terrain or to avoid existing structures, the following design and installation criteria may be safely employed:

$$R = \frac{360 \text{ degrees}}{\emptyset \text{ degrees}} \times \frac{L}{2\pi}$$

$\emptyset$  = Allow deflection angle per joint  
 $L$  = Length of pipe  
 $R$  = Minimum Radius of curvature

NOTE: When  $\emptyset$  is maximum R will be minimum.

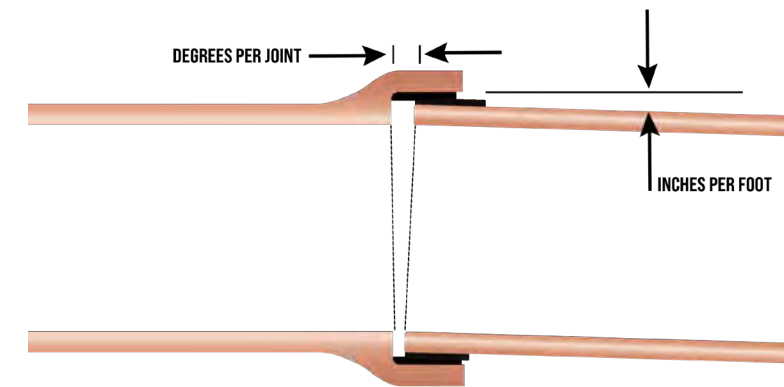

NOMINAL PIPE SIZE	MAX. DEFL. AT EACH JOINT	APPROX. MAX. DEFL./FT. OF PIPE	MINIMUM RADIUS OF CURVATURE - FEET						
			6' PIPE LENGTH	5-1/2' PIPE LENGTH	5' PIPE LENGTH	4-1/2' PIPE LENGTH	4' PIPE LENGTH	3' PIPE LENGTH	2' PIPE LENGTH
4"-12"	2.39°	1/2"	144'	132'	120'	108'	96'	72'	48'
15" - 24"	1.79°	3/8"	192'	176'	160'	144'	128'	96'	64'
27" - 36"	1.21°	1/4"	288'	264'	240'	213'	189'	142'	95'
39" - 42"	0.92°	3/16"	N/A	352'	320'	280'	249'	187'	125'

# SPEED SEAL<sup>®</sup>

## JOINT SYSTEM

### HIGH-PERFORMANCE LEAK RESISTANT PIPE JOINT

The **SPEED SEAL**<sup>®</sup> joint system is a proprietary joint design used on vitrified clay pipe manufactured by Gladding, McBean. The joint consists of a two-part polyurethane sealing compound that is factory-applied to the pipe ends, providing a durable and leak-resistant connection for sanitary sewer applications.

### Innovative Joint Design

The **SPEED SEAL**<sup>®</sup> joint utilizes a bell and spigot configuration designed to create a compression during assembly:

- ✓ Spigot End: Smooth external surface
- ✓ Bell End: Raised ridge that compresses during assembly

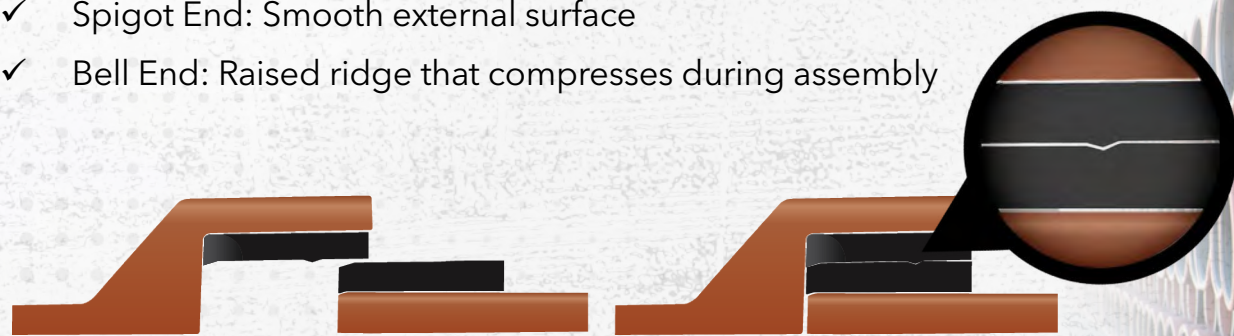

**SPEED SEAL**<sup>®</sup> bell and spigot joint configuration showing compression of the polyurethane seal during assembly.



Vitrified clay pipe with Gladding, McBean Speed Seal<sup>®</sup> joint system

### Performance & Testing

- ✓ Meets watertight joint requirements of ASTM C425
- ✓ Tested internally using 10 psi hydrostatics testing

### Application Guidelines

- ✓ Apply lubricant full strength
- ✓ Coat each joint surface immediately prior to assembly
- ✓ Ensure all dirt and debris are removed before installation

*When assembled, the bell ridge and spigot deform slightly, producing uniform compression around the full circumference of the joint, ensuring a watertight seal.*

In addition to being a manufacturer of Vitrified Clay Pipe, Gladding, McBean provides professional support to the **Engineering Community** and is a resource for technical information during both the design and construction of your project. We will assist agencies with the identification and resolution of construction challenges and/or provide information to the contractor to assist in the proper installation of our products.

We're a proud partner with the **National Clay Pipe Institute (NCPI)**



Scan the QR code to download the manuals

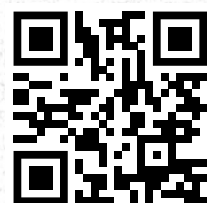

## Strong Supply. **On-Time.** Where you need it.

Gladding, McBean primarily utilizes transportation partners and its subsidiary, **Material Transport**, to ensure reliable and timely delivery of products throughout the Western United States and select extended regions, aligned with customer needs.

### Strategic Stocking Locations

Our inventory is positioned across key western states to ensure fast, reliable delivery and maximum availability.

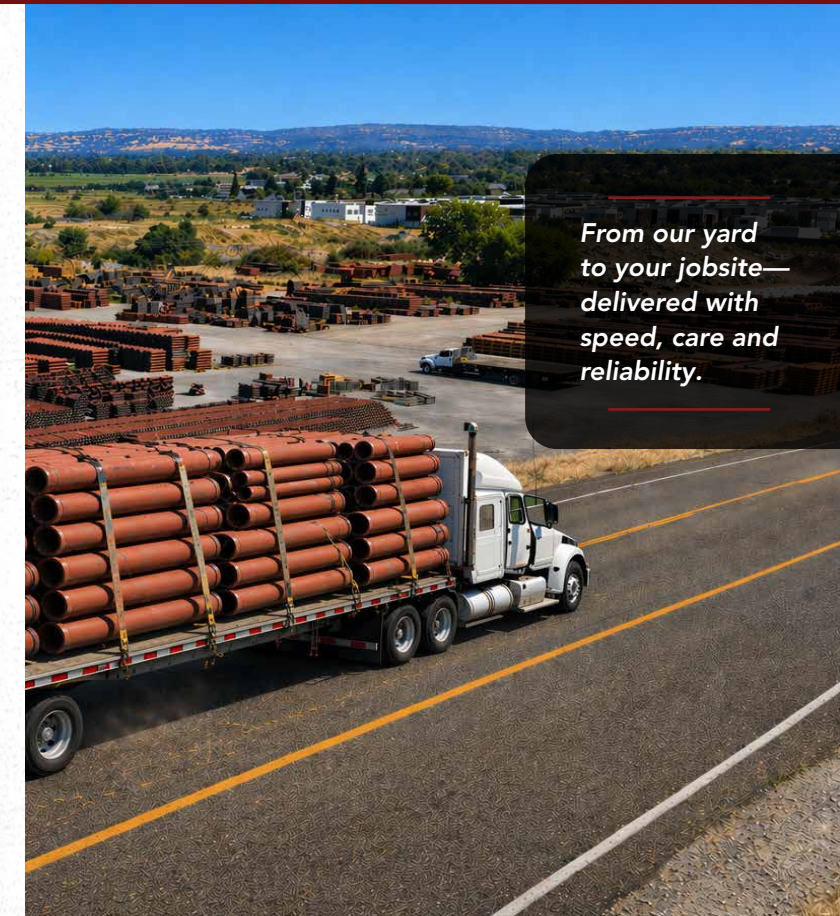

From our yard to your jobsite—delivered with speed, care and reliability.

### LARGE INVENTORY

Ready to meet project demands.

### STRATEGIC LOCATIONS

Stocked across the West for faster, more efficient delivery.

### ON-TIME DELIVERY

Reliable schedules powered by **Material Transport.**

### CUSTOMER FOCUSED

Committed to keeping your projects moving.



# GLADDING, McBEAN

Clay Tiles • Terra Cotta • Pottery • Pipe

*A Division of*

**Basalite® Building Products**

## Northern California

601 7th St  
Lincoln, CA 95648  
800-964-2529

## Contact Our Sales Team

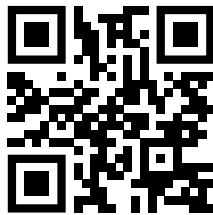

## Southern California

4301 E. Firestone Blvd  
South Gate, CA 90280  
323-568-1860

[www.gladdingmcbean.com](http://www.gladdingmcbean.com) | [info@gladdingmcbean.com](mailto:info@gladdingmcbean.com)