

Gladding, McBean

COTSWOLD CLAY ROOF TILE

Blended Red



Kiln-Ran #8 Mix



Spanish Bay Blend



COTSWOLD CLAY ROOF TILE

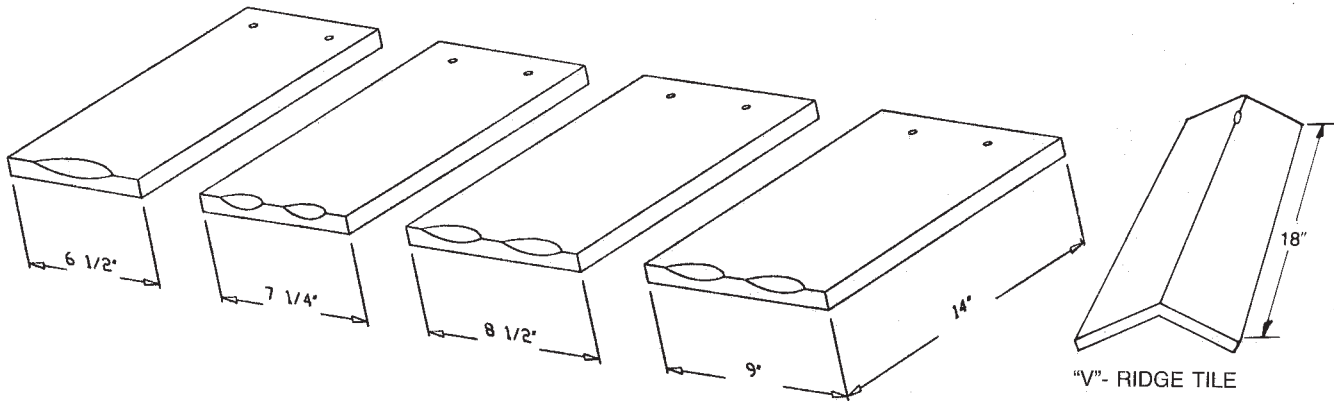

SPECIFICATIONS

A. MATERIALS

- Gladding, McBean Cotswold Shingle Tile has a wire-cut face with scalloped edges. The length of the tile is 14" with 4 widths of 6 1/2", 7 1/4", 8 1/2" and 9" wide. Tile is generally laid with an 8" random exposure. Tiles may also be laid with a random exposure. Meeting requirements of ASTM C-1167.
- Under eave shall be (specify one):
 - Clay tile cant strip 3" x 16" x 3/4".
 - 1" x 2" wood cant strip.
- Hips and ridges shall be "V" type clay tile, 18" long, laid with an exposure of 14". (Specify pitch of roof.)
- Cement Mortar: The mortar used under the hip, ridge and gable tile shall be Type M by proportions per U.B.C. Table 24A. This mix is basically (by volume) 1 part Type I cement (or masonry cement) to 3 parts damp plaster sand.

B. COLOR shall be (specify one):

- Blended Red.
- Kiln-run No. 8 Mix.
- Spanish Bay Blend.

C. UNDERLAY—The underlayments described are very conventional and in accordance with many building code requirements including I.C.B.O. Uniform Building Code and the City of Los Angeles Building Code. Sweep roof surface broom clean. Cover knot holes with tin. Specify desired weight of underlay as follows:

For Pitches of less than 4/12:

- Lay two layers of 30# felt at right angles to roof surface, nail to secure in place as code requires. Mop solidly 25# per square between layers and on top of layers with hot asphalt.

For Pitches of 4/12 and greater:

- Lay one layer of 30# or 40# felt. Lay with 4" head lap and a 6" side lap. Nail to secure in place as code requires.

NOTE: HOT MOP UNDERLAYMENT IS HIGHLY RECOMMENDED.

D. TILE FASTENERS—Tile shall be fastened by (specify one of the following):

- Nails—Non-Corrosive. Sufficient length shall give 3/4" penetration. (Consult manufacturer of special roof deck materials for additional nailing specifications.)
- Fasteners—To be installed per project specifications using applicable 300 series Stainless Steel or Galvanized Tyle Tye Systems, as manufactured by Newport Fasteners, per I.C.B.O. 3362 and provided by Gladding, McBean. Consult factory regarding applicable deck attachment and accessories.

"V" - TILE HIP & RIDGE

Angle	Roof Pitch
153 degrees	3/12
141 degrees	4/12
128 degrees	5.5/12
115 degrees	7.5/12
90 degrees	12/12

E. METHOD OF APPLICATION:

- Alternate rows shall be started at eave.
- All hip and ridge tile shall be laid in cement mortar and fastened with non-corrosive nails or wire ties. Refer to "Clay Roof Tile Specifications and Suggested Installation Details" showing desired construction of hips and ridges.
- All tile in contact with cement mortar shall be immersed in water for at least 2 minutes before laying to avoid drying out the mortar before setting and curing.

Shade Blending: After 75 to 100 tiles are installed, examine the application at a distance from ground level for straight, true lines and good color blend. This should be done at regular intervals during installation to insure an attractive and acceptable roof. Blending of shade is particularly important to avoid streaks or "hot spots." Acceptable blending cannot be done at the factory or on the ground; it can only be done as the tile is applied.

G112b 2,500 CP 08/14/06



GLADDING, McBEAN

a division of **PABCO**
building products, LLC

601 7th Street / P.O. Box 97, Lincoln, CA 95648
(800) 964-2529 Ext.204 (916) 645-3341 Ext.204
Fax (916) 645-1723

www.gladdingmcbean.com